

INSTRUCTION MANUAL

Velocity/Acceleration Monitor

Model 566



Robertshaw Industrial Products
1602 Mustang Drive
Maryville, TN 37801
Telephone: (865) 981-3100 Fax: (865) 981-3168

NUMBER

909GF272C

P-2409

TABLE OF CONTENTS

I DESCRIPTION 1
 1.1 General 1
 1.2 Model Identification 1

II SPECIFICATIONS 1
 2.1 Environmental 1
 2.2 Electrical 2
 2.3 Performance 2

III INSTALLATION 2
 3.1 General 2
 3.2 Mounting, Internal Sensor 2
 3.3 Mounting, Remote Sensor 2
 3.4 Electrical Connections 2

IV OPERATION 5
 4.1 Description of Controls and Adjustments 5
 4.2 Calibration – Setting the Alarms 5

V SPARE PARTS 8
 5.1 Model 566 Spare Parts 8
 5.2 Remote Transducer Spare Parts 8

VI DIMENSIONS 9
 6.1 Model 566 and Remote Transducer Dimensions 9

ILLUSTRATIONS

3-1 Electrical Connections 3
 3-2 Transducer Wiring, Internal and Remote 4
 3-3 Output Current Signal Wiring 4
 3-4 Remote Reset 4
 3-5 Machine Power Monitor 4
 3-6 Alarms #1 and #2 2-4
 3-7 AC Power 4
 4-1 Operating Controls 6
 4-2 Alarm #1 Velocity Setting 7
 4-3 Alarm #1 Acceleration Setting 7
 4-4 Alarm #2 Setting 8
 6-1 Dimensions 9

Section I – DESCRIPTION

1.1 GENERAL

The Robersshaw Model 566 Velocity/Acceleration Monitor is a versatile vibration detection instrument designed to provide a 4-20 maDC output signal and two field adjustment solid state alarm outputs, one with adjustable time delay. The device is field selectable for Velocity or Acceleration modes of operation with each having two ranges of vibration coverage. Switching from Velocity to Acceleration or Acceleration to Velocity is accomplished with no degradation of operation. The alarms can be set for Normally Open or Normally Closed and for “latched” or “unlatched” states. The Time Delay operates on Alarm #1 only and is adjustable from 0.5 to 15 seconds. Alarm #2 has no Time Delay, therefore is an immediate alarm or shutdown when the vibration exceeds the setting of Alarm #2.

1.2 MODEL IDENTIFICATION

Identify instrument models in accordance with the description and variations listed in each table. Dashes are used in the model number only in those spaces as indicated in the example below.

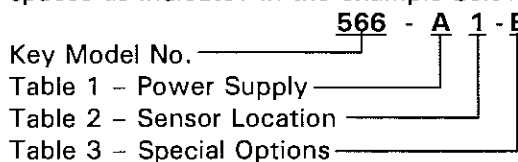

KEY MODEL NO.

Model No.	Description
566	Velocity or Acceleration Monitor with 4-20 maDC output and two adjustable solid state alarms. Housed in an explosion-proof enclosure.

Table 1 – POWER SUPPLY

Desig.	Description
A	120 VAC, $\pm 10\%$, 50/60 Hz.
B	240 VAC, $\pm 10\%$, 50/60 Hz.

Table 2 – SENSOR LOCATION

Desig.	Description
1	Internally mounted sensor
2	Remote mounted sensor in an explosion-proof conduit. Can be mounted up to 1,000 feet from the Model 566 using ungrounded twisted pair wires.

Table 3 – Special Options

Desig.	Description
None	No special option.
E	Enclosure(s) painted with gray epoxy enamel.

Section II – SPECIFICATIONS

2.1 ENVIRONMENTAL

Operating Temperature Range: -40 to +176°F (-40 to +80°C)
 Storage Temperature Range: -65 to +200°F (-54 to +93°C)
 Humidity: 95% RH @ +100°F (+37°C)
 Shock: 75g’s for 11ms
 Housing: FM approved and CSA Certified Explosion-proof for Class I, Div. 1, Groups C & D; Class II, Div. 1, Groups E, F, & G. CSA certified for Enclosure 4 (watertight) – equivalent to NEMA 4.
 Remote Transducer Housing: ... FM approved Explosion-proof for Class I, Div. 1, Groups B, C, & D; Class II, Div. 1, Groups E, F, & G. NEMA 4 (watertight). CSA certified Explosion-proof for Class I, Div. 1, Groups C & D; Class II, Div. 1, Groups E, F, & G. CSA enclosure 4 (watertight) – equivalent to NEMA 4.

2.2 ELECTRICAL

Supply Voltages 120 VAC, $\pm 10\%$, 50/60 Hz.
240 VAC, $\pm 10\%$, 50/60 Hz.

Input Signal:

Velocity Low Range: 0-1.5 in./sec. RMS
High Range: 0-3 in./sec. RMS
Acceleration ... Low Range: 0-5 G's RMS
High Range: 0-10 G's RMS

Output Signal 4-20 maDC (not isolated)

Output Signal Load Limit 750 Ohms Maximum

Solid State Relay Rating Triac, 2 amp, 120 or
240 VAC inductive or
non-inductive. Leak
rate 1 ma maximum.

NOTE:

AC CURRENT ONLY – Minimum Triac Load Current
50 ma.

Time Delay Field Adjustable 0.5 to 15 seconds
(alarm #1 only).

2.3 PERFORMANCE

Accuracy:

Relay Setpoint $\pm 10\%$ of setting with a
repeatability of 2%

Analog output $\pm 5\%$ of span
(4-20 maDC)

Supply and Load Variation Less than $\pm 0.1\%$

Frequency Response Flat response
8 Hz. to 1 KHz.

Output Current Limit 22 ma maximum

Section III – INSTALLATION**3.1 GENERAL**

Examine the instrument for possible shipping damage. **IMPORTANT:** If for any reason it is determined that parts should be returned to the factory, please notify the nearest Robertshaw sales representative prior to shipment. Each unit must be properly packaged to prevent damage. Robertshaw assumes no responsibility for equipment damaged in shipment due to improper packaging.

3.2 MOUNTING, INTERNAL SENSOR UNIT

The vibration sensitive axis of the instrument is perpendicular to its mounting base. Therefore, the instrument must be mounted in a plane that will detect the vibratory motion for which monitoring is desired. The instrument may be mounted at any location along the length of machines containing rotating shafts. The preferable location being parallel to the rotating shaft. Do not mount the instrument perpendicular to the ends of rotating shafts unless the end-play or end-thrust measurement is desired. Normally, bent shafts, unbalances on the rotating mass of the shaft, worn bearings, and other anomalies are detected near the bearing housings and parallel to the shaft. See Figure 6-1 for dimensions.

3.3 MOUNTING, REMOTE SENSOR UNIT

The remote sensor of the instrument is to be mounted per the instructions given in Section 3.2 above. The instrument itself should be in a location in accordance with good instrument practice, avoiding extremes of temperature and humidity. It may be mounted or oriented in any position at a distance up to 1000 feet from the remote sensor utilizing ungrounded twisted pair wires. See Figure 6-1 for dimensions.

3.4 ELECTRICAL CONNECTIONS

All electrical connections should be made in accordance with the appropriate figures as noted below. The use of color coded wire is recommended. The wiring should be within a grounded metal conduit. The wiring between the Model 566 and a remotely mounted sensor is ungrounded twisted pair. If this wiring is in grounded metal conduit that also contains power lines, the twisted pair from the remote sensor must be of the shielded type.

TRANSDUCER: The wires from the transducer (internal or remote) connect to the corresponding terminals on the Model 566 that are marked "XDCR." See Figure 3-2.

OUTPUT CURRENT SIGNAL: The 4-20 maDC output wiring is to be done in accordance with Figure 3-3.

REMOTE RESET: This is used with the "Latch" mode of operation. The wiring from the Model 566 to the remote switch (usually a normally-open, momentary contact, pushbutton switch) must be ungrounded. See Figure 3-4.

CAUTION

Do not ground these terminals nor connect an external power source to them. **Failure to comply will result in permanent damage to the unit.**

MACHINE POWER MONITOR: This is used to eliminate high vibration indication on Alarm #1 and to disable the 4-20 mA output (locking the output at 4 mA) whenever the machine being monitored is shutting down. When using this feature, power is applied to the MACHINE POWER MONITOR terminals in conjunction with the power that is applied to the machine being monitored. This is usually done by connecting these terminals to the supply terminals of the machine being monitored. This is not normally required, however, when not using this feature continuous power must still be applied to the machine power terminals during operation of the model 566. Continuous power may be obtained by connecting jumpers between the AC POWER terminals and the MACHINE POWER MONITOR terminals. Voltage applied to these terminals must be the same as the supply power. Polarity is not important.

ALARMS #1 AND #2: These are solid state relays. The output load is connected in series with the corresponding solid state relay and connected to either 120 VAC or 240 VAC.

AC POWER: This is continuous line power in accordance with nameplate data (either 120 or 240 VAC, 50/60 Hz.) See Figure 3-7.

NOTE

These relays will not operate on DC. Minimum Triac Load Current 50 ma. See Figure 3-6.

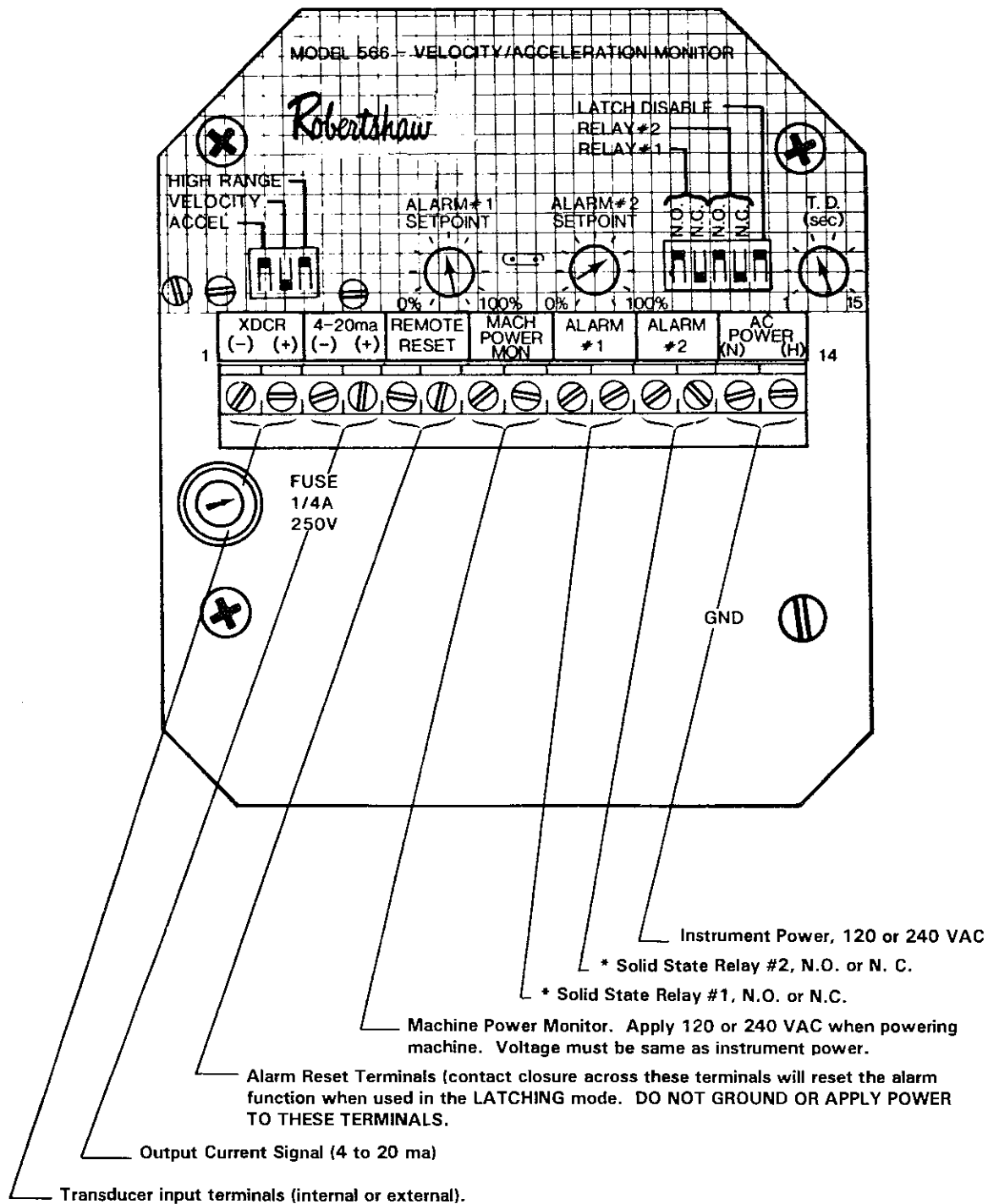

*Minimum Triac Load Current is 50 ma.

Figure 3-1

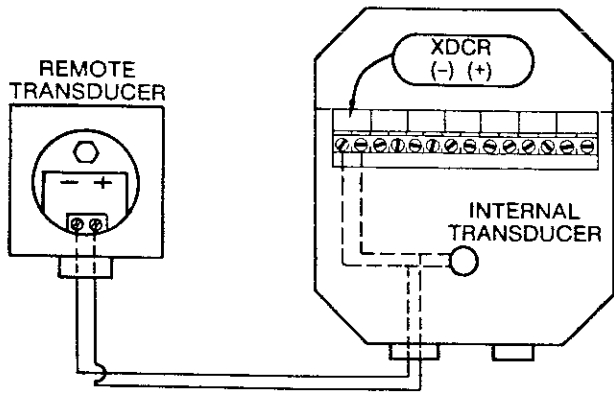

Figure 3-2: Transducer Wiring
Polarity must be observed.

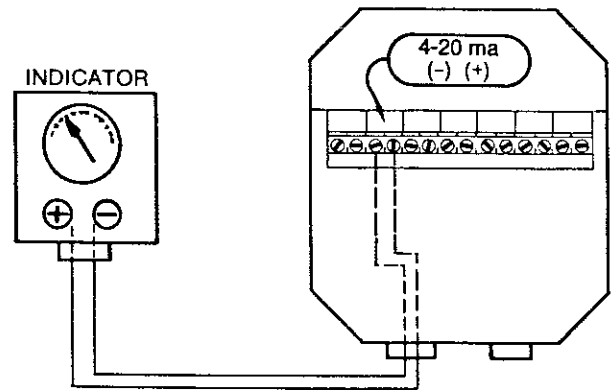

Figure 3-3: Output Current Wiring
Polarity must be observed.

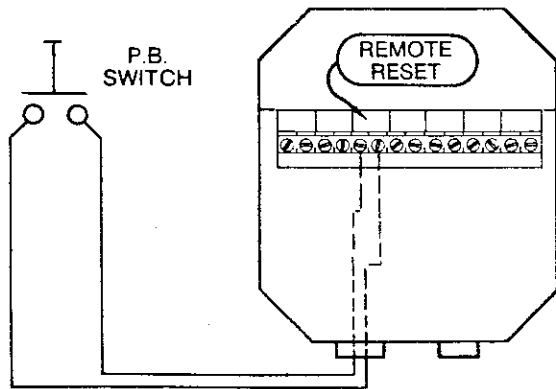

Figure 3-4: Remote Reset Wiring.

AC POWER MUST BE APPLIED FROM MONITORED MACHINE OR JUMPERED FROM AC SUPPLY POWER

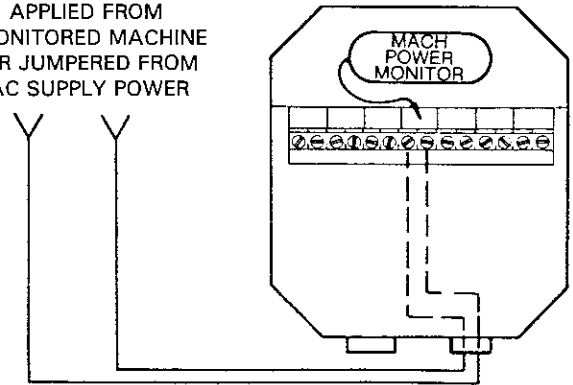
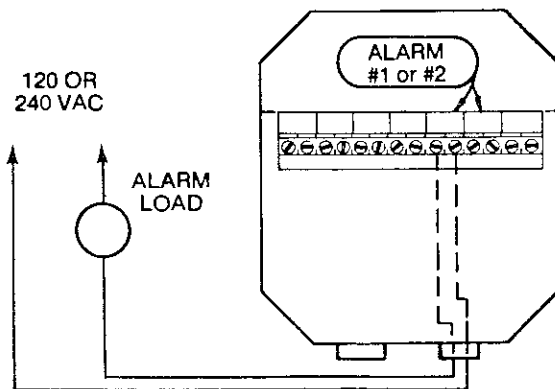

Figure 3-5: Machine Power Monitor Wiring
Voltage must be same as AC supply power.



Note:
Minimum Triac Load Current is 50 ma.

Figure 3-6: Alarms Wiring.

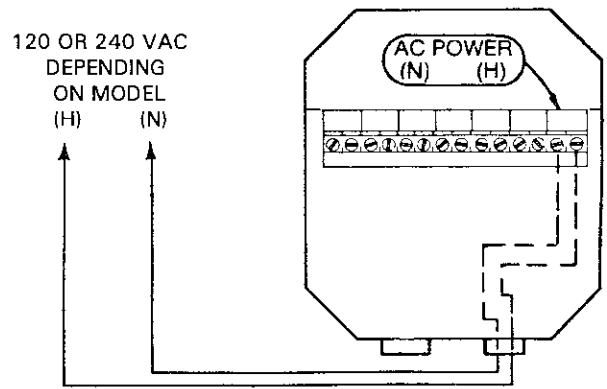

Figure 3-7: AC Supply Power Wiring
Polarity must be observed.

Section IV – OPERATION

4-1 DESCRIPTION OF CONTROLS AND ADJUSTMENTS (See Figure 4-1)

VELOCITY SPAN ADJ.: Factory calibrated for 20 maDC at 100% input.

ACCELERATION SPAN ADJ.: Factory calibrated for 20 maDC at 100% input.

ACCELERATION SWITCH: Set in the UP position for monitoring acceleration and DOWN for monitoring velocity.

VELOCITY SWITCH: Set in the UP position monitoring velocity and DOWN for monitoring acceleration.

HIGH RANGE SWITCH: Set in the UP position for the high range of velocity or acceleration and DOWN for the low range.

ZERO ADJUSTMENT: Factory calibrated for 4 maDC at 0% input.

ALARM #1 SETPOINT: This is the calibration adjustment for Alarm #1. Adjust this control for the desired vibration alarm value in percent of the operating range. The control is marked 0 to 100% with 10 subdivisions.

ALARM #2 SETPOINT: This is the calibration adjustment for Alarm #2. Adjust this control for the desired vibration alarm value in percent of the operating range. The control is marked from 0 to 100% with 10 subdivisions.

RELAY #1 N.O. SWITCH: Place this switch in the UP position if Relay #1 is to be OPEN in the unalarmed condition (vibration is below the alarm setpoint) or in the DOWN position if Relay #1 is to be CLOSED in the unalarmed condition.

RELAY #1 N.C. SWITCH: Place this switch in the UP position if Relay #1 is to be CLOSED in the unalarmed condition (vibration is below the alarm setpoint) or in the DOWN position if Relay #1 is to be OPEN in the unalarmed condition.

RELAY #2 N.O. SWITCH: Place this switch in the UP position if Relay #2 is to be OPEN in the unalarmed condition (vibration is below the alarm setpoint) or in the DOWN position if Relay #2 is to be CLOSED in the unalarmed condition.

RELAY #2 N.C. SWITCH: Place this switch in the UP position if Relay #2 is to be CLOSED in the unalarmed condition (vibration is below the alarm setpoint) or in the DOWN position if Relay #2 is to be OPEN in the unalarmed condition.

LATCH DISABLE SWITCH: Place this switch in the UP position for the relays NOT to latch when alarmed and therefore will not remain in the

alarmed state when the vibration drops below the alarm setpoint. Place the switch in the DOWN position for the relays TO LATCH when alarmed and will remain in the alarmed state until "unlatched." To unlatch the relays, momentarily close the REMOTE RESET switch.

TIME DELAY (T.D.) (Seconds): This is the Time Delay adjustment for Alarm #1 ONLY. This delay is adjustable from 0.5 to 15 seconds.

4.2 CALIBRATION – SETTING THE ALARMS

NOTE:

All settings below are only the recommendation of Robertshaw. The actual settings used must be determined by the user.

WARNING

Do not remove the cover of the instrument with power applied in an explosive atmosphere.

ALARM #1:

Set the TIME DELAY to maximum. Start the machine that is to be monitored and allow it to reach its normal operating speed and load conditions. When this condition is attained, slowly turn RELAY #1 SETPOINT adjustment counter-clockwise until RELAY #1 ALARM TRIP INDICATOR turns ON. Note the percentage value on the dial at this point. The trip indicator is not affected by the Time Delay so it will turn on immediately when the above condition is met.

Velocity Mode: Look at Figure 4-2 and find the percentage value obtained above along the vertical axis on the left of the chart. Obtain the Final Setpoint Value along the horizontal axis from the chart and turn RELAY #1 SETPOINT adjustment clockwise to this value.

ACCELERATION MODE: Look at Figure 4-3 and follow the same procedure as in Velocity Mode above.

TIME DELAY: A time delay of 0.5 to 15 seconds is provided for Relay #1. The purpose of this delay is to allow the unit to ignore relatively short duration transitory vibration, such as might be encountered during start-up, speed changes, and/or shutdown of the machine. This Time Delay is calibrated by first calibrating the Alarm #1 setpoint, as outlined above, and then setting the Time Delay at a value slightly greater than the anticipated duration of this type of vibration, but short enough that no damage will be suffered by the machine being monitored.

ALARM #2:

This setpoint should be used as an immediate alarm/shutdown in the event of catastrophic failure (vibration) of any component. It should be set at a value above the setting of Alarm #1 as determined by Figure 4-4 for velocity and acceleration. This alarm does not have any time delay adjustment.

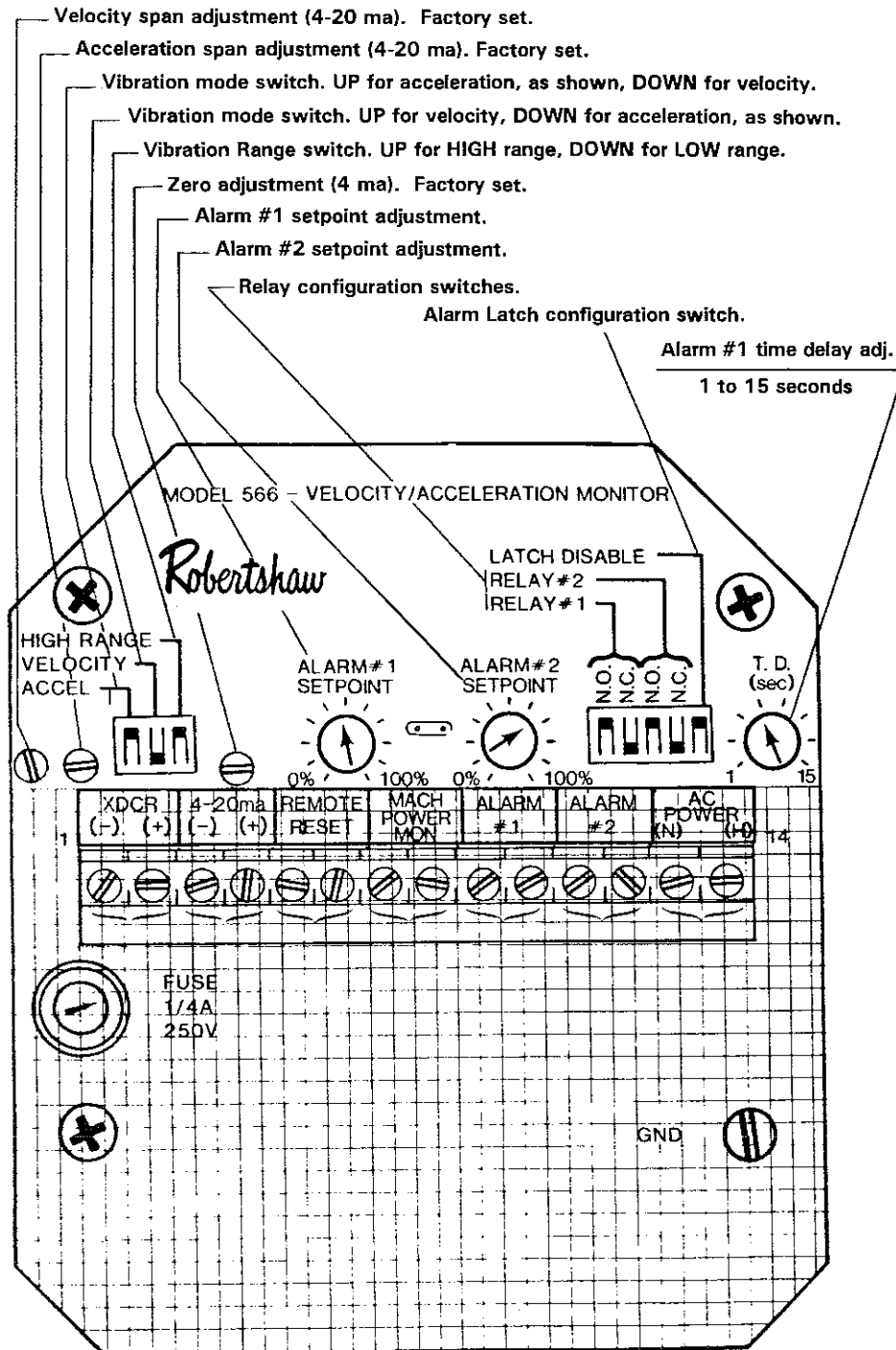
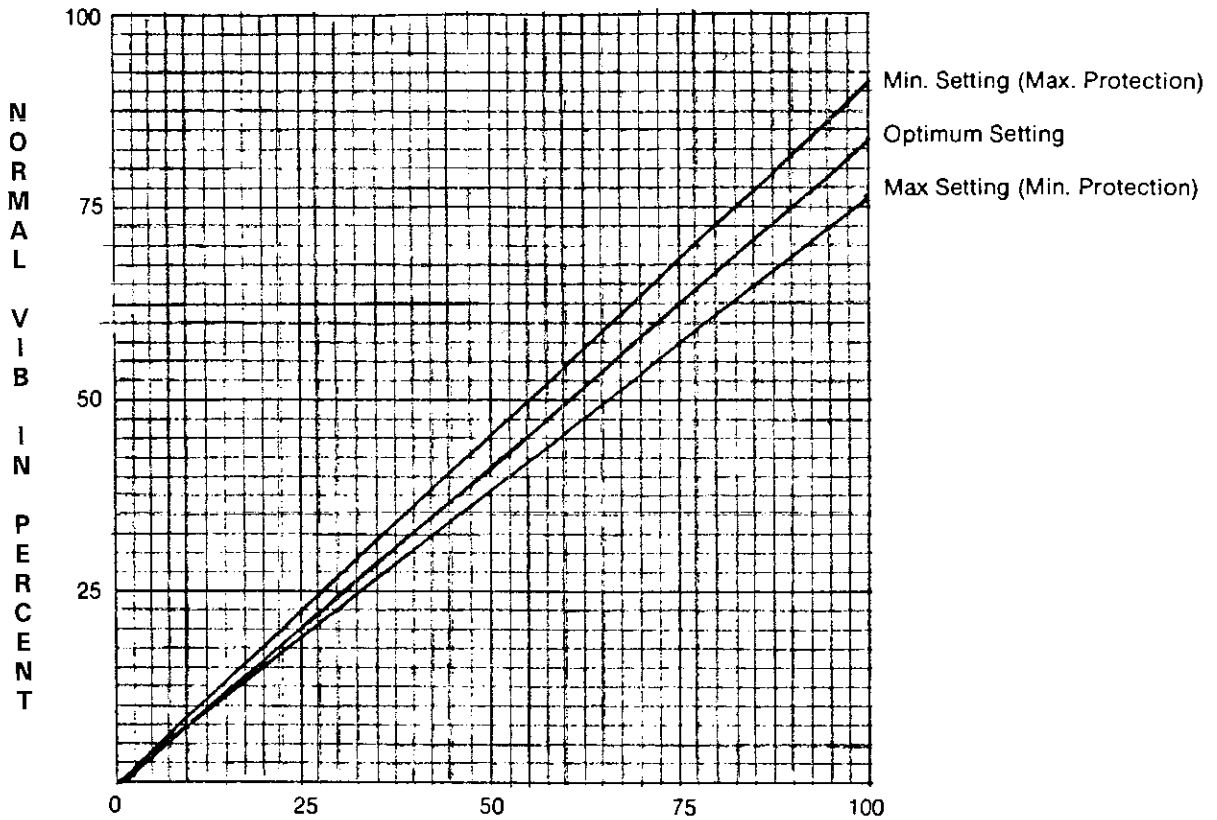
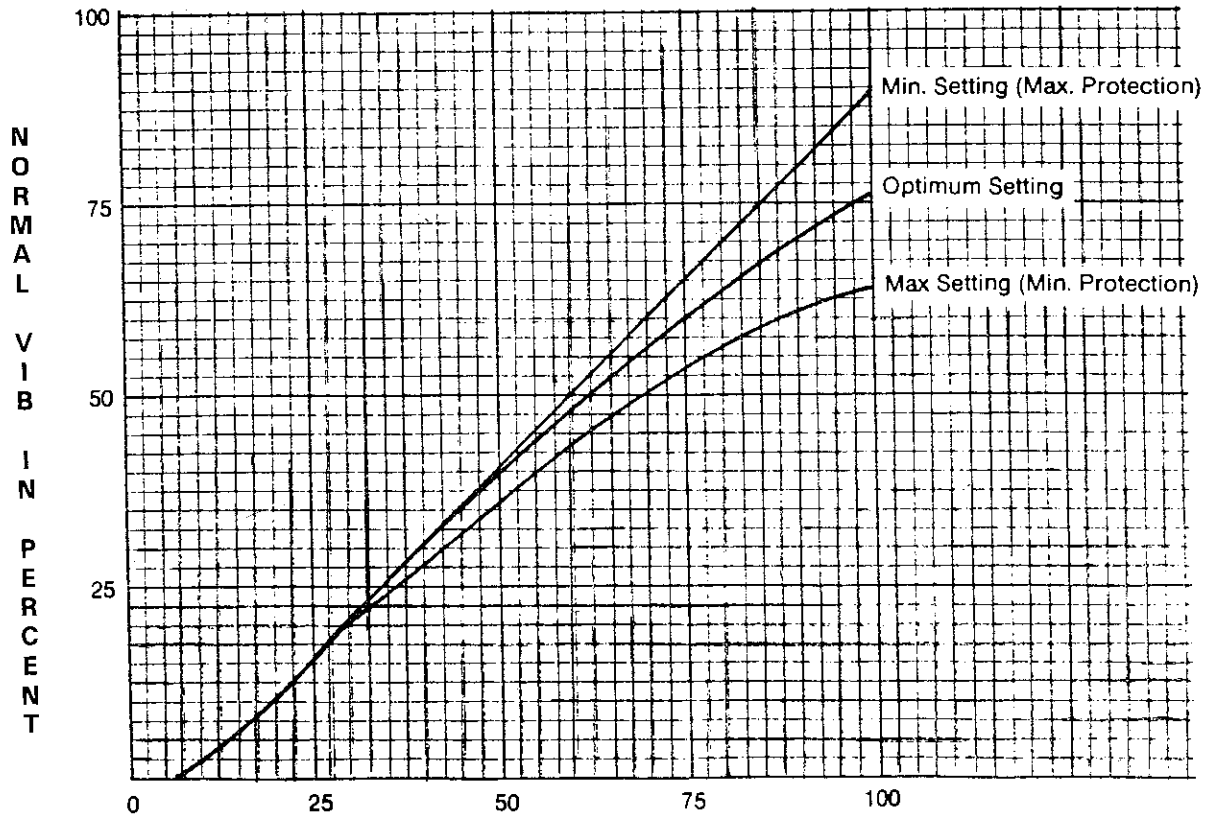

Figure 4-1: OPERATING CONTROLS



FINAL SETTING IN PERCENT OF SPAN
Figure 4-2: ALARM #1, VELOCITY SETTING



FINAL SETTING IN PERCENT OF SPAN
Figure 4-3: ALARM #1, ACCELERATION SETTING

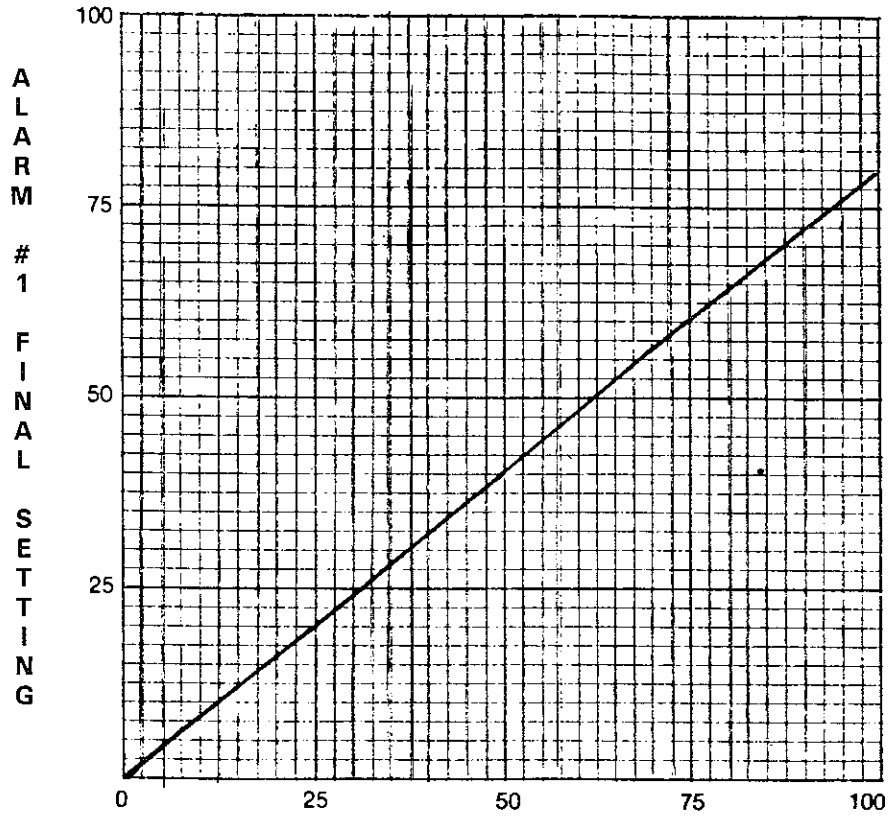

ALARM #2 SETTING
Figure 4-4: Alarm #2 Setting

Section V – SPARE PARTS

5.1 SPARE PARTS FOR MODEL 566

Robertshaw

Part Number Description

Model 566

- 018KB030 Cover, Protective
- *019KB005 Plate, Mounting, Accelerometer
- 040KB458-02 Cover, Enclosure – Standard
- 040SA104-04 Cover, Enclosure – Epoxy Painted
- 040KB560 Housing – Standard
- 040SA104-03 Housing – Epoxy Painted
- 044KX130-01 PCA, I/O – 120 VAC
- 044KX130-02 PCA, I/O – 240 VAC
- 044KX132 PCA, Logic
- 044KX134-01 PCA, Power Supply – 120 VAC
- 044KX134-02 PCA, Power Supply – 240 VAC
- 560KB070 Gasket, Cover
- *580KB008-01..... Accelerometer

*Denotes part not used in Model 566 With Remote Transducer option.

5.2 SPARE PARTS FOR REMOTE TRANSDUCER

Robertshaw

Part Number Description

Model 904GC337

- 904GC337 Transducer, Remote – Standard
- 904GC337-01..... Transducer, Remote – Epoxy Painted
- 019KB101 Plate, Mounting, Accelerometer
- 039KB017 Housing – Standard
- 039KB017-01..... Housing – Epoxy Painted
- 044KX152 PCA, Termination
- 560KB051-01..... O-Ring
- 580KB008-01..... Accelerometer
- 904GB802-02 Cover, Enclosure – Standard
- 904GB802-05 Cover, Enclosure – Epoxy Painted

Section VI - DIMENSIONS
Model 566 and Remote Transducer Dimensions

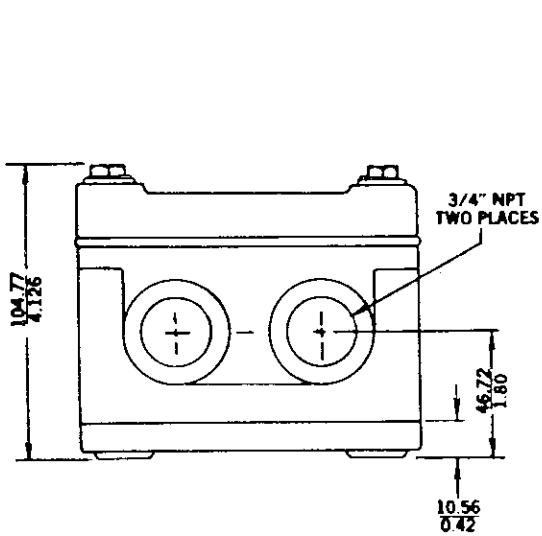
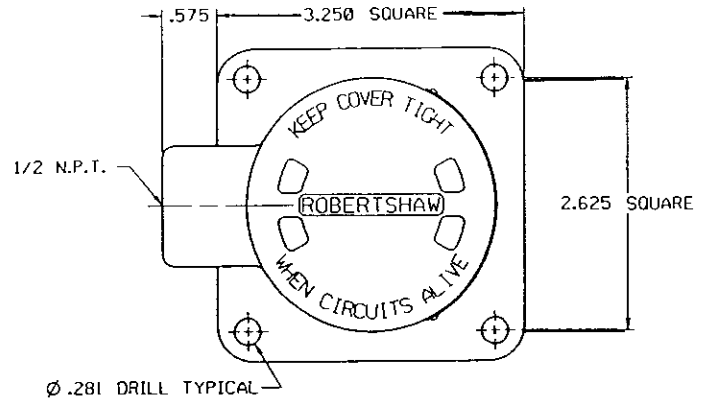
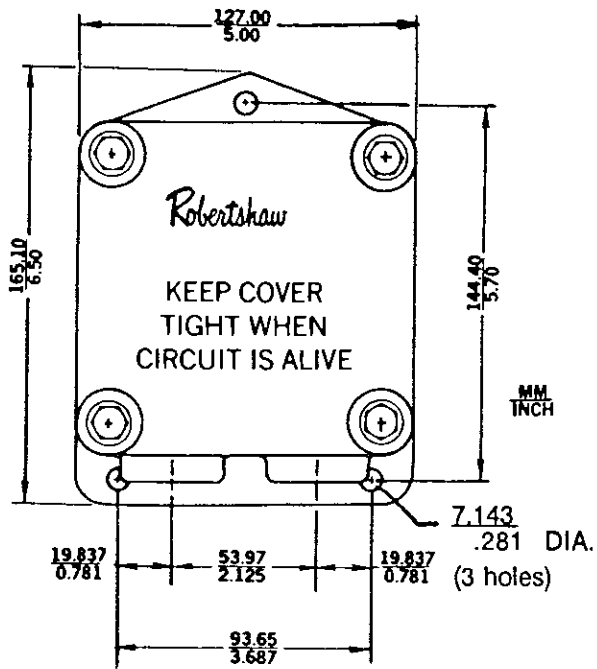

BASIC MODEL 566

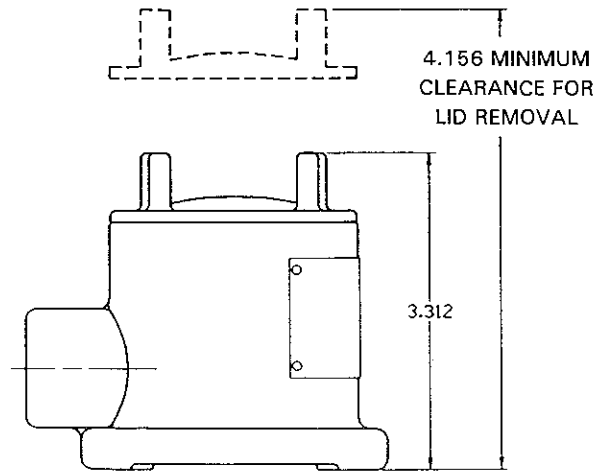

REMOTE TRANSDUCER

Figure 6-1: DIMENSIONS