

Solid State Relays Industrial, 2-Pole ZS Type RA2A

CARLO GAVAZZI

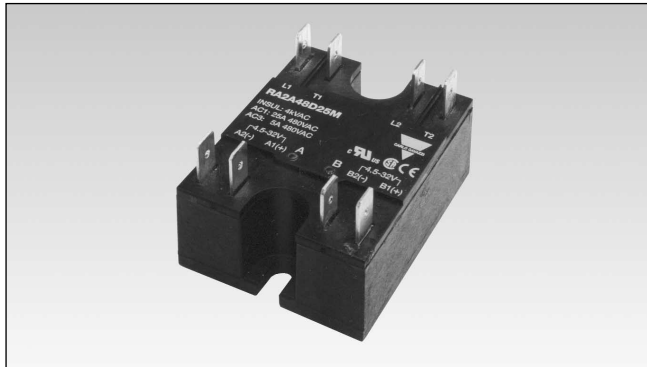

- 2-Pole AC Solid State Relay
- Zero switching
- For resistive and inductive AC loads
- Direct copper bonding (DCB) technology
- LED indication
- Rated operational current: 25 and 40 AACrms
- Rated operational voltage: 230 - 600 VACrms
- Input range: 4.5 to 32 VDC
- Non-repetitive peak voltage: Up to 1200 Vp
- Opto-isolation: 4000 VACrms

Preliminary data sheet

Product Description

This 2-pole industrial relay minimises the space requirements in a control cabinet without compromising performance. By applying an input voltage on control A, the corresponding output semiconductor is activated at the first zero crossing of the line voltage.

The same applies to control B. LEDs indicate the control status of each pole. The optimised design is free of moulding mass to reduce internal mechanical stress. The RA2A..M types have been specially customised for demanding inductive loads.

Type Selection

Switching mode	Rated operational voltage	Rated operational current	Control voltage	Non-rep. voltage	Load type
A: Zero switching	23: 230 VAC 40: 400 VAC 48: 480 VAC 60: 600 VAC	25: 25 A 40: 40 A	D: 4.5 to 32 VAC	23: 650 V _p 40: 850 V _p 48: 1200 V _p 60: 1200 V _p	M: Inductive

Selection Guide

Rated operational voltage	Non-rep. voltage	Control voltage	Rated operational current	
			25 AACrms	40 AACrms
230 VACrms	650 V _p	4.5 to 32 VDC	RA2A23D25	RA2A23D40
400 VACrms	850 V _p	4.5 to 32 VDC	RA2A23D25M	RA2A23D40M
480 VACrms	1200 V _p	4.5 to 32 VDC	RA2A40D25	RA2A40D40
600 VACrms	1200 V _p	4.5 to 32 VDC	RA2A40D25M	RA2A40D40M
			RA2A48D25	RA2A48D40
			RA2A48D25M	RA2A48D40M
			RA2A60D25	RA2A60D40
			RA2A60D25M	RA2A60D40M

Input Specifications

Control voltage range	4.5 to 32 VDC
Pick-up voltage	4.25 VDC
Drop-out voltage	2 VDC
Input current per pole	10 mA
Response time pick-up @ 50 Hz	10 ms
Response time drop-out @ 50 Hz	10 ms

Housing Specifications

Weight	Approx. 110 g
Housing material	Noryl GFN 1, black
Base plate	Aluminium, nickel-plated Copper, nickel-plated
25, 40 A 40 A (M type)	
Relay	M5 ≤ 1.5 Nm
Mounting screws	
Mounting torque	6.3 mm
Fast on terminals	

Ordering Key

RA 2 A 48 D 25 M

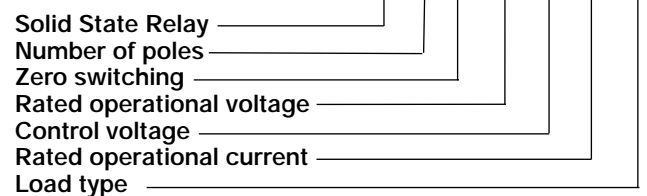

Heatsink Dimensions (load current versus ambient temperature)

RA 2....25.

Load current [A]	Thermal resistance [K/W]						Power dissipation [W]
	20	30	40	50	60	70	
50	1.11	0.96	0.80	0.65	0.49	0.33	64
45	1.37	1.19	1.01	0.83	0.65	0.47	56
40	1.67	1.46	1.25	1.04	0.83	0.63	48
35	1.97	1.73	1.48	1.23	0.99	0.74	41
30	2.4	2.1	1.79	1.49	1.19	0.90	33
25	3.0	2.6	2.2	1.9	1.5	1.12	27
20	3.9	3.4	2.9	2.4	1.9	1.45	21
15	5	5	4	3.4	2.7	2.0	15
10	8	7	6	5	4	3.2	9
5	18	15	13	11	9	7	5

Ambient temp. [°C]

RA 2....40

Load current [A]	Thermal resistance [K/W]						Power dissipation [W]
	20	30	40	50	60	70	
80	0.66	0.54	0.43	0.31	0.20	0.09	87
72	0.84	0.71	0.58	0.45	0.32	0.19	76
64	1.07	0.92	0.77	0.62	0.46	0.31	66
56	1.37	1.19	1.01	0.84	0.66	0.48	56
48	1.7	1.5	1.3	1.08	0.87	0.65	46
40	2.2	1.9	1.6	1.3	1.1	0.81	37
32	2.8	2.4	2.1	1.7	1.4	1.04	29
24	4	3	3	2.4	1.9	1.4	21
16	6	5	5	4	3	2.3	13
8	13	11	9	8	6	5	6

Ambient temp. [°C]

RA 2....40M

Load current [A]	Thermal resistance [K/W]						Power dissipation [W]
	20	30	40	50	60	70	
110	0.19	0.12	0.05	-	-	-	145
100	0.29	0.21	0.13	0.05	-	-	128
90	0.42	0.32	0.23	0.14	0.04	-	112
85	0.57	0.46	0.36	0.25	0.14	0.03	97
70	0.77	0.65	0.52	0.39	0.27	0.14	82
65	1	0.9	0.74	0.59	0.43	0.28	68
50	1.4	1.2	1.1	0.9	0.7	0.48	55
45	2	1.7	1.5	1.2	1	0.74	43
30	3	2	2	1.7	1.4	1	31
20	4	4	3	3	2	1.6	20
10	9	8	7	5	4	3	10

Ambient temp. [°C]

Heatsink Selection

Carlo Gavazzi Heatsink (see Accessories)	Thermal resistance...	...for power dissipation
No heatsink required	---	N/A
RHS 300	5.00 K/W	> 0 W
RHS 100	3.00 K/W	> 25 W
RHS 45A	2.70 K/W	> 60 W
RHS 45B	2.00 K/W	> 60 W
RHS 90	1.35 K/W	> 60 W
RHS 45A plus fan	1.25 K/W	> 0 W
RHS 45B plus fan	1.20 K/W	> 0 W
RHS 112	1.10 K/W	> 100 W
RHS 301	0.80 K/W	> 70 W
RHS 90 plus fan	0.45 K/W	> 0 W
RHS 112 plus fan	0.40 K/W	> 0 W
RHS 301 plus fan	0.25 K/W	> 0 W
Consult your distribution	> 0.25 K/W	N/A
Infinite heatsink - No solution	---	N/A

Note: Add the currents of both poles and compare with datasheets for proper heatsink. Each pole can handle up to the maximum current specified. Example: Each pole of the RA2A23D25 can handle a maximum of 25 A.

Insulation

Rated insulation voltage Input to output	≥ 4000 VACrms
Rated insulation voltage Output to case	≥ 4000 VACrms

Accessories

Heatsinks
DIN rail adapter
Varistors
Fuses

For further information refer to "General Accessories".

Applications

This relay is designed for use in applications in which it is exposed to high surge conditions. Care must be taken to ensure proper heatsinking when the relay is to be used at high sustained currents. Adequate electrical connection between relay terminals and cable must be ensured.

Thermal characteristics
The thermal design of Solid State Relays is very important.

It is essential that the user makes sure that cooling is adequate and that the maximum junction temperature of the relay is not exceeded.

If the heatsink is placed in a small closed room, control panel or the like, the power dissipation can cause the ambient temperature to rise. The heatsink is to be calculated on the basis of the ambient temperature and the increase in temperature.

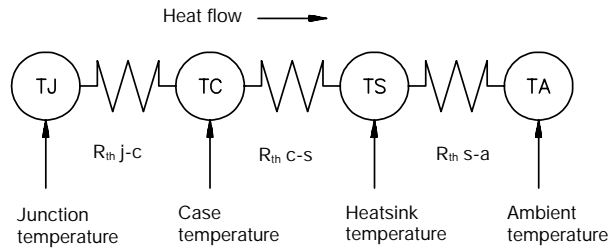

Thermal resistance:
 $R_{th j-c}$ = junction to case

$R_{th c-s}$ = case to heatsink
 $R_{th s-a}$ = heatsink to ambient

Thermal Specifications

	RA2A...25.	RA2A...40	RA2A...40M
Operating temperature	-20° to 70°C	-20° to 70°C	-20° to 70°C
Storage temperature	-20° to 80°C	-20° to 80°C	-20° to 80°C
Junction temperature	≤ 125°C	≤ 125°C	≤ 125°C
R_{th} junction to case			
1 pole	1 K/W	1 K/W	0.92 K/W
2 pole	0.5 K/W	0.5 K/W	0.46 K/W
R_{th} junction to ambient	≤ 20 K/W	≤ 20 K/W	≤ 20 K/W

Applications

A single two pole relay in a three phase application. Star and Delta (Economy switch)

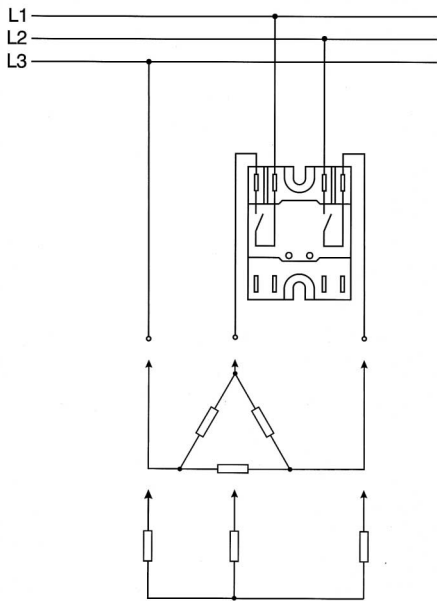

A single two pole relay and a single pole relay connected on a three phase application. Delta, star and star with a neutral point.

